

## TOP VIEW

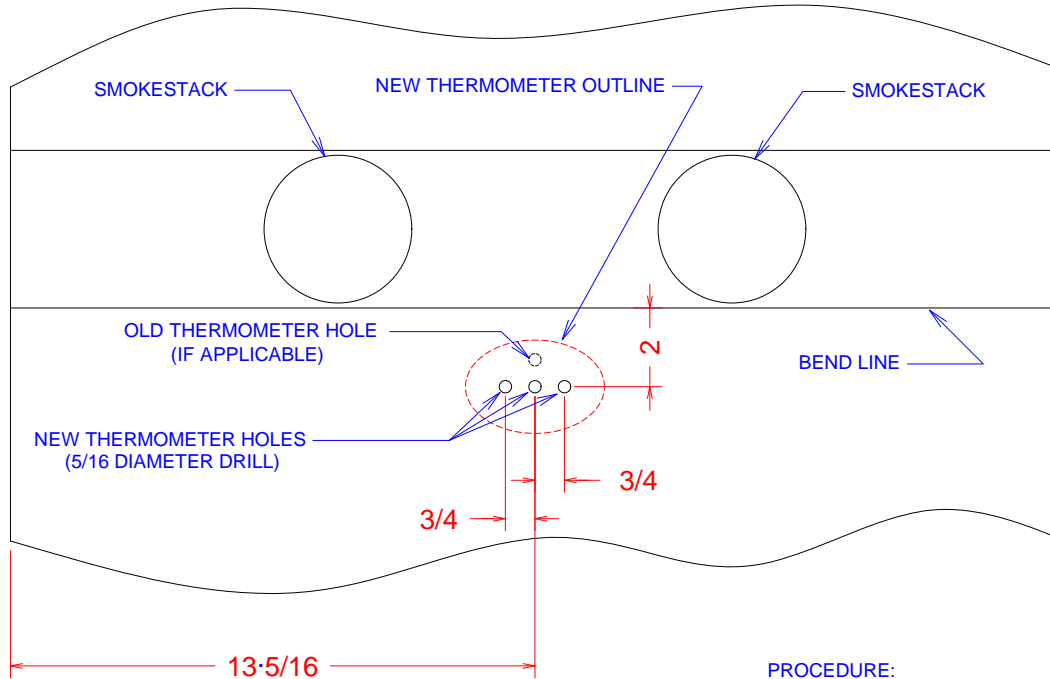

TOOLS REQUIRED:  
 - TAPE MEASURE  
 - DRILL WITH 5/16" BIT  
 - STRAIGHTEDGE  
 - PENCIL  
 - SMALL ADJUSTABLE WRENCH

## SIDE VIEW

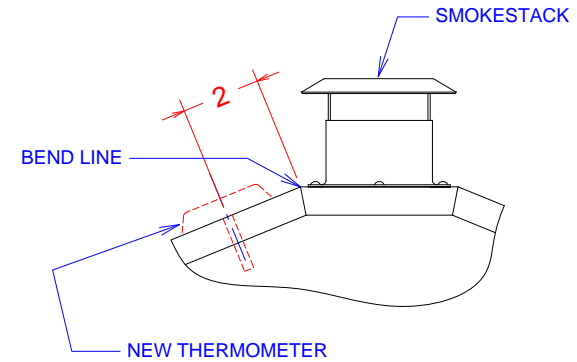

### PROCEDURE:

- 1) IF APPLICABLE, REMOVE OLD THERMOMETER. (NOTE: DUE TO THE DIFFERENT CONFIGURATION OF THE NEW THERMOMETER, THE OLD THERMOMETER HOLE CANNOT BE USED. THE DIMENSIONS GIVEN IN THESE INSTRUCTIONS WILL ALLOW THE NEW THERMOMETER TO SIT CORRECTLY, AT THE SAME TIME COVERING UP THE OLD THERMOMETER HOLE.)
- 2) MEASURE 2" DOWN FROM THE TOP BEND LINE ON THE FRONT DIAGONAL SURFACE, APPROXIMATELY 4-6" FROM THE CENTER (LEFT-TO-RIGHT). MARK THIS LOCATION VERY LIGHTLY WITH PENCIL. MOVE 4-6" TO THE OTHER SIDE OF CENTER AND REPEAT.
- 3) ALIGN STRAIGHTEDGE WITH THESE TWO MARKS AND DRAW A LINE AT THE CENTER (LEFT-TO-RIGHT). KEEP LINE SHORT AND MAKE SURE IT IS NEAR THE CENTER SO LINE WILL BE HIDDEN BY THERMOMETER AFTER IT IS INSTALLED.
- 4) MEASURE 13-5/16" FROM EITHER SIDE AND MAKE A MARK ON THE SHORT LINE IN STEP 3.
- 5) MEASURE 3/4" TO THE RIGHT FROM MARK IN STEP 4, AND MARK THE LINE DRAWN IN STEP 3. REPEAT THIS FOR THE LEFT SIDE.
- 6) DRILL THE THREE LOCATIONS YOU JUST MARKED. BE AS ACCURATE AS POSSIBLE AND BE CAREFUL TO NOT ALLOW THE DRILL TO SLIP. (NOTE: IF YOUR GRILL HAS A STAINLESS LID, WE RECOMMEND USING OIL TO LUBRICATE THE DRILL BIT. POUR A SMALL AMOUNT OF OIL INTO A CUP AND DIP THE END OF THE BIT IN THE OIL BEFORE DRILLING. REPEAT THIS SEVERAL TIMES FOR EACH HOLE. THIS WILL KEEP THE BIT FROM OVERHEATING AND BURNING. IF THE BIT STARTS TO SMOKE DURING DRILLING, STOP AND DIP IT IN THE OIL AGAIN TO COOL IT OFF.)
- 7) MAKE SURE THERE ARE NO BURRS OR ROUGH EDGES AROUND THE HOLES THAT MAY PREVENT THE THERMOMETER FROM SITTING FLUSH ON THE GRILL. CHECK THE GRILL INTERIOR ALSO. REMOVE ANY BURRS IF NECESSARY.
- 8) REMOVE THE NUTS FROM THE THREADED STEMS OF THE THERMOMETER. PLACE THERMOMETER INSIDE TRIM RING. PLACE THERMOMETER AND RING ON GRILL SO THAT THE THREADED STUDS AND THE PROBE SLIDE INTO THE THREE HOLES YOU JUST DRILLED.
- 9) TIGHTEN THE TWO NUTS USING ADJUSTABLE WRENCH. DO NOT OVERTIGHTEN!!